



BIFLOW SB CYL

Bifurcated Cylindrical Axial Flow Fan

BIFLOW SB CYL

Product Overview

- 3 standard sizes from 400mm to 630mm
- Air volume flow rates up to 4.501 m³/s
- Static pressures up to 201 Pa
- Suitable for operating temperatures up to +200°C
- Available in **AC**



A range of bifurcated axial fans, specially developed with motor out of the airstream to handle more hostile air movement applications.

High Temperature

Class H motors out of the airstream are not effected by contaminates in the ventilated air. Suitable for elevated temperatures up to +200°C

Efficient Performance

High efficiency adjustable pitch aerofoil impellers are provided with blades made from high quality pressure die cast aluminium.

Corrosion resistance

The fan casing is dip galvanised after fabrication to BS 729 offering enhanced corrosion resistance.

Weather Resistance

The fans are suitable for external mounting as standard.

Long life

Motor is isolated from hot and contaminated air, prolonging the life of the fan.

Warranty

Each SB has a 12 month warranty.

Construction

Constructed from sheet steel with both motor and impeller mounted within the length of the unit casing.

Motor

Motors are foot mounted, totally enclosed fan cooled, IP55, with sealed for life bearings with a standard industrial paint finish and Class H insulation to EN 60034-5.

Impeller

Adjustable pitch aerofoil impellers are provided with blades made from high quality pressure die cast aluminium (LM6), natural finish. Impellers are factory set at an angle to provide maximum performance. The hubs are manufactured from die cast aluminium alloy (LM24). Assembled impellers are to be dynamically balanced to ISO 14694 Grade G6.3.

Typical Applications

- Kitchen Extract
- Spray Booths
- Hot Gas Situations
- Corrosive Atmospheres
- Boiler Houses
- Heavy Industrial

Contents

Page	Information
3	Performance Range Curves
4	Performance, SFP & Electrical Data
5	Sound Data
6	Dimensional Data
7	Accessories

Product Coding

Code	Reference
SB	Product Range
400	Diameter (400/500/630)
/	
4	Number of Poles (2/4/6)
-	
3	Voltage Supply (Single Phase / Three Phase)
AC	Motor Type (AC/EC)
A - Z	Additional Coding (A - Z) Product Variants
e.g.	SB400 / CYL4 - 3AC

BIFLOW SB CYL



Performance Range Curves

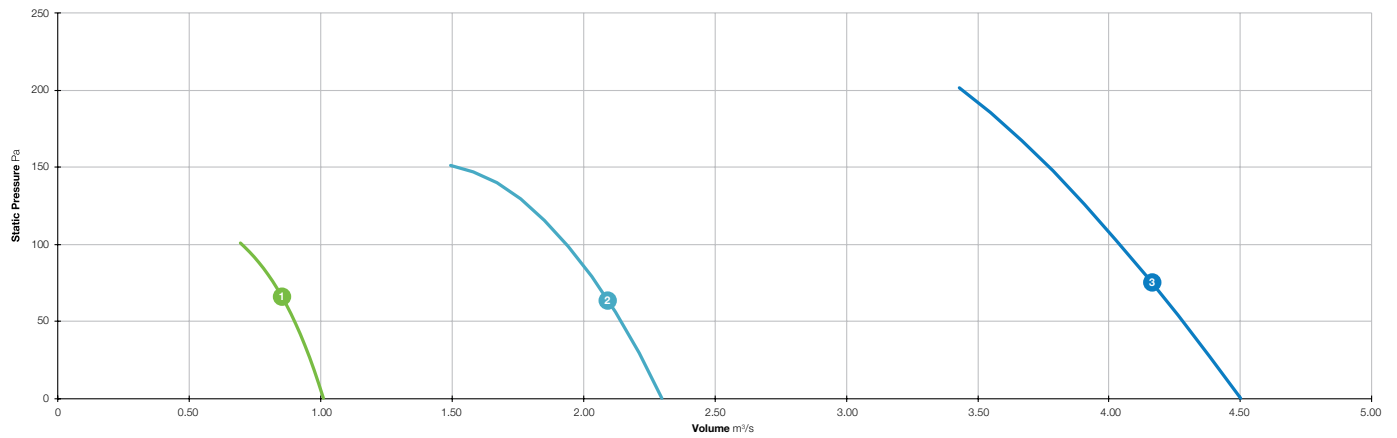

- 1 SB400 / CYL4-3
- 2 SB500 / CYL4-3
- 3 SB630 / CYL4-3

BIFLOW SB CYL



Performance, SFP & Electrical Data

Three Phase 380V to 415V / 50Hz

Product Code	Speed r/min	Airflow	Airflow m ³ /s @ Static Pressure Pa							At Best Efficiency Point	Electrical Data			dBA @ 3m
			0	25	50	75	100	150	200	Output kW	Peak Amps	SC	Δ / Y	
SB400-CYL4-3	1400	m ³ /s	1.010	0.961	0.900	0.821	0.699	-	-	0.250	0.69	3.80	Mains	55
SB500-CYL4-3	1415	m ³ /s	2.300	2.230	2.140	2.040	1.920	1.520	-	0.750	1.65	10.90	Mains	62
SB630-CYL4-3	1410	m ³ /s	4.501	4.393	4.280	4.162	4.039	3.771	3.442	2.200	4.43	30.90	Mains	70

Data provided is at standard air density of 1.2 kg/m³.

Exempt from ErP of the European Parliament.

Peak Amps @ 400V / 3PH / 50Hz.

The overall A-weighted sound pressure level is at a distance of 3m with spherical free-field propagation. It is expressed in dB re-20μPa and is presented for comparative purposes only.

BIFLOW SB CYL



Sound Data

Three Phase 380V to 415V / 50Hz

Product Code	Speed r/min		Sound Power Level dBW @ Octave Band Hz								Total dB
			63Hz	125Hz	250Hz	500Hz	1kHz	2kHz	4kHz	8kHz	
SB400-CYL4-3	1400	Inlet	80	77	76	72	71	69	66	56	84
SB500-CYL4-3	1415	Inlet	80	79	78	77	79	76	73	66	86
SB630-CYL4-3	1410	Inlet	89	87	85	85	85	85	83	78	95

Data provided at standard air density of 1.2 kg/m³.
Tests and preparation of the sound data have been carried out in accordance with BS 848 Part 2:1985 at 50% peak pressure.
The Sound Power Level Spectra are in dB re-1pW.

BIFLOW SB CYL



Dimensional Data

Three Phase

Product Code	A	B	C	E	F	G	Weight kg
SB400-CYL4-3	400	475	450	8	12	450	29
SB500-CYL4-3	500	585	450	12	12	560	47
SB630-CYL4-3	630	715	570	12	12	690	78

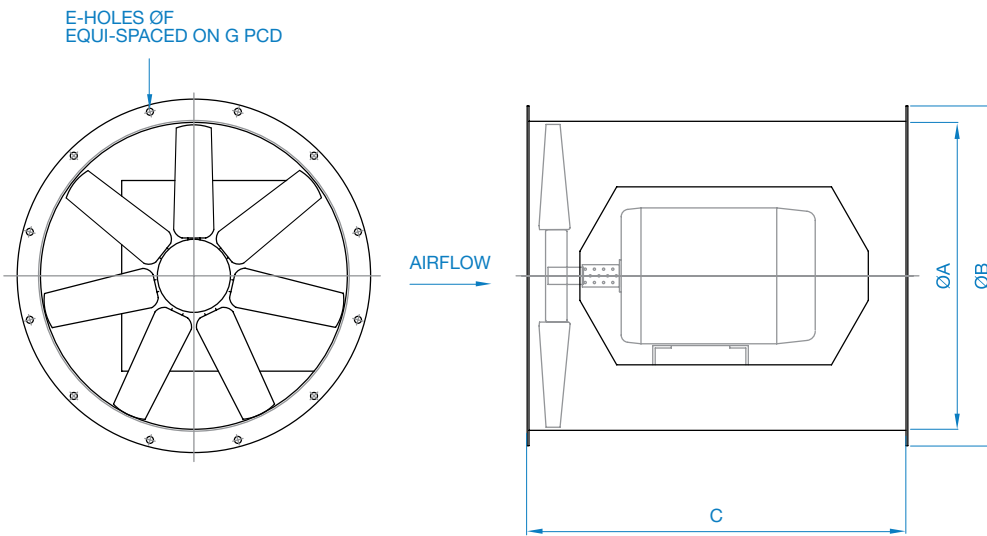

Dimensions are in mm.

BIFLOW SB CYL



Accessories

Three Phase

Product Code	Ancillary Pack*	AV Mounts (set of 4)	Bell Mouth Inlet	Flanged Damper	Flanged Silencer 1D Podded	Flanged Silencer 1D Unpodded
SB400-CYL4-3	APK400SBCYL/002	062-002	241B-0400-BELL	019-0400-STD	068-0400-1DEP	068-0400-1DENP
SB500-CYL4-3	APK500SBCYL/003	062-003	241B-0500-BELL	019-0500-STD	068-0500-1DEP	068-0500-1DENP
SB630-CYL4-3	APK630SBCYL/003	062-003	241B-0630-BELL	019-0630-STD	068-0630-1DEP	068-0630-1DENP

Product Code	Flanged Silencer 2D Podded	Flanged Silencer 2D Unpodded	High Temperature Flexible Connectors (each)	Impeller Side Guard	Matching Flanges (each)	Mounting Feet (each)	Wiring Diagram
SB400-CYL4-3	068-0400-2DEP	068-0400-2DENP	063-0400-PU250	078C-0400-C	061B-0400	060B-0400	152-600
SB500-CYL4-3	068-0500-2DEP	068-0500-2DENP	063-0500-PU250	078C-0500-C	061B-0500	060B-0500	152-600
SB630-CYL4-3	068-0630-2DEP	068-0630-2DENP	063-0630-PU250	078C-0630-C	061B-0630	060B-0630	152-600

* Consists of Flexible Connections, Matching Flanges, AV Mounts and Mounting Feet.

AV MOUNTS

Accessories



- Fits directly to mounting feet
- Rubber with steel insert
- Supplied as set of 4, complete with fixings

Product Code	A	B	C	D	E	F	G	Weight kg
062-002	64	50	43	5.5	20	M6	Ø7	0.040
062-003	80	57	45	5	32	M8	12 x 9	0.102

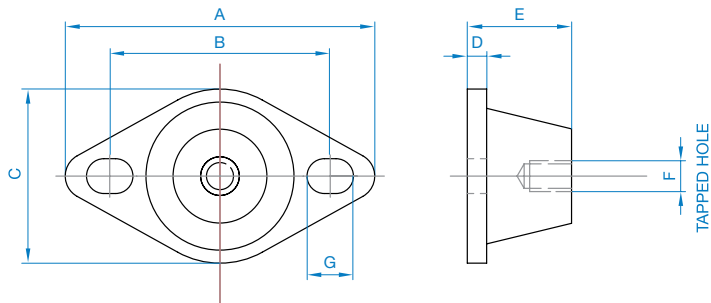

Dimensions are in mm.

BELL MOUTH INLET

Accessories

- For improved airflow in end of duct applications
- Fixed directly to fan case flange
- Hot dip galvanised steel



Single Phase 220V to 240V / 50Hz or 60Hz

Product Code	Fan Dia. A	B	C	D	E	Weight kg
241B-0400-BELL	400	485	3	75	515	4.5
241B-0500-BELL	500	585	3	93	630	6.2
241B-0630-BELL	630	715	3	105	780	9.0

*Inlet cone

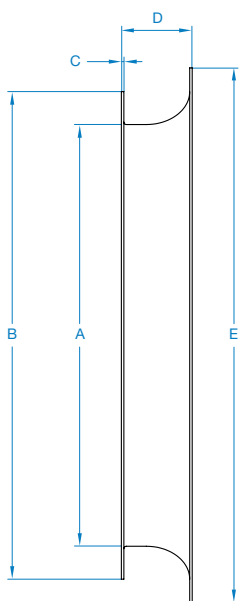

Dimensions are in mm.

FLANGED DAMPER

Accessories



- Prevents reverse flow of air when fan is not operating
- Fixed directly to fan case flange
- Hot dip galvanised steel
- Galvanised steel butterfly type blades
- Suitable for horizontal or vertical (upward airflow) mounting

Product Code	Fan Dia. A	B	C	D	E	G	H	J	Weight kg
019-0400-STD	400	475	220	270	3.0	8	12	450	9.0
019-0500-STD	500	585	220	315	3.0	12	12	560	18.0
019-0630-STD	630	715	250	420	3.0	12	12	690	25.0

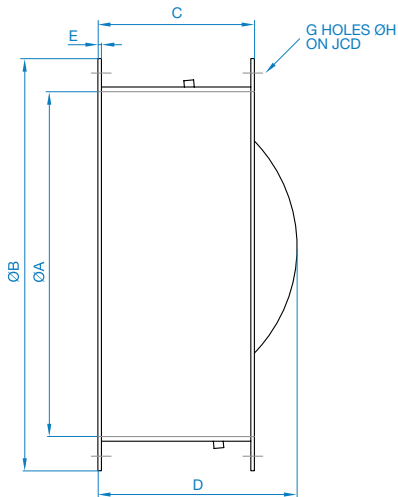

Dimensions are in mm.

FLANGED SILENCER

Accessories



- Ideal for bolting directly to fan flange
- Ideal for all axial fans
- Ideal for cross talk elimination
- Ideal for flexible or spiral ducting

Overview

Elta Fans are able to provide 2 types of cylindrical silencers as standard; Type DENP (without pod) and DEP (with pod), these are categorised as follows; Compact Silencers (ENP / EP), Standard Silencers (ENP / EP / Melinex).

Construction

Both types are rigidly constructed in galvanised sheet steel, with a highly absorbent sound attenuating lining between the outer casing and the inner perforated steel lining. The end faces of the silencer has a series of threaded holes for direct mounting to the fixing flange/flexible collar. The EP (podded versions) will provide an improved level of attenuation. The inner acoustic pod is constructed from perforated steel sheet with a sound absorbent infill.

Melinex lined silencers must be used to prevent grease impregnation into the acoustic media for kitchen extract applications as prescribed in DW/172 HVAC Specification For Kitchen Ventilation Systems. For Melinex insertion losses, please contact Elta Fans. Silencers can be provided with differing lengths: 1D = 1 times diameter, 2D = 2 times diameter. The Velocity through podded silencer should not exceed 15m/s.

Silencer Attenuation

To determine the sound level of a fan fitted with a silencer, the dynamic insertion loss should be subtracted from the sound power level spectrum (dBW) of the fan. This should be done for the entire octave band mid-frequency spectrum. The fan dBW ratings and silencer attenuation apply equally to in duct applications, with a silencer connected between the fan and the duct system.

Dynamic Insertion Loss

The silencer attenuation is defined as the “dynamic insertion loss”. The values quoted in the tables represent the difference between the sound power level of a fan and silencer combination (dBW) and that of the fan alone (dBW). The dynamic insertion losses shown are the attenuations recorded under ideal working conditions. The achieved attenuation will vary according to the air velocity and flow pattern in the airways. Noise regeneration can occur at higher velocities, especially in EP silencers.

Square / Rectangular Silencers

In highly noise sensitive areas, where the circular silencers cannot achieve the necessary attenuation levels, Elta can design and build optional splitter silencers for greater effect.

FLANGED SILENCER

Dynamic Insertion Loss & Pressure Graphs

Dynamic Insertion Loss

Fan Size	Silencer Length	Silencer Type	Insertion Loss @ Octave Band (Hz)							
			63	125	250	500	1k	2k	4k	8k
0400-0560	1D	ENP	-2	-5	-6	-9	-13	-11	-6	-6
		EP	-4	-6	-8	-11	-18	-19	-17	-14
	2D	ENP	-4	-8	-12	-17	-23	-17	-12	-10
		EP	-7	-10	-12	-21	-26	-26	-24	-22
0630	1D	ENP	-3	-4	-9	-15	-15	-8	-7	-6
		EP	-4	-6	-8	-17	-23	-20	-18	-10
	2D	ENP	-6	-8	-13	-22	-22	-13	-12	-9
		EP	-8	-11	-16	-27	-32	-31	-29	-19

Podded Silencers Pressure Graphs

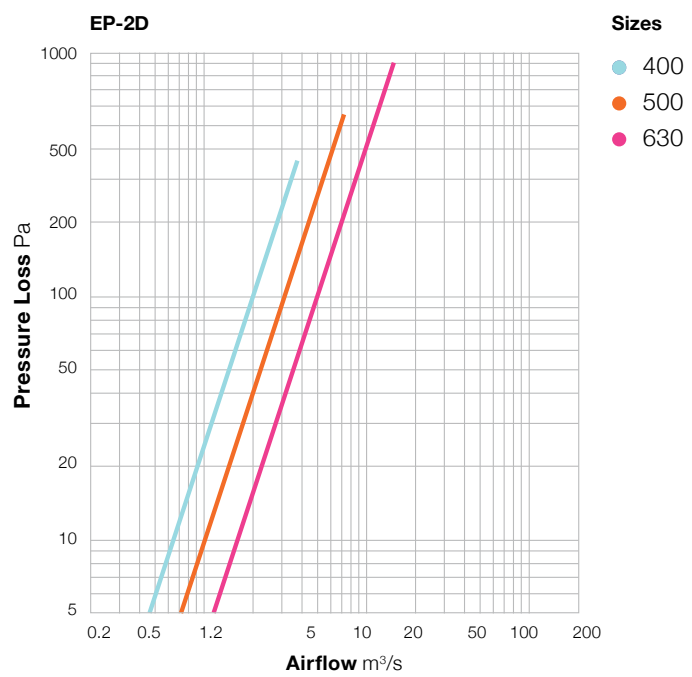
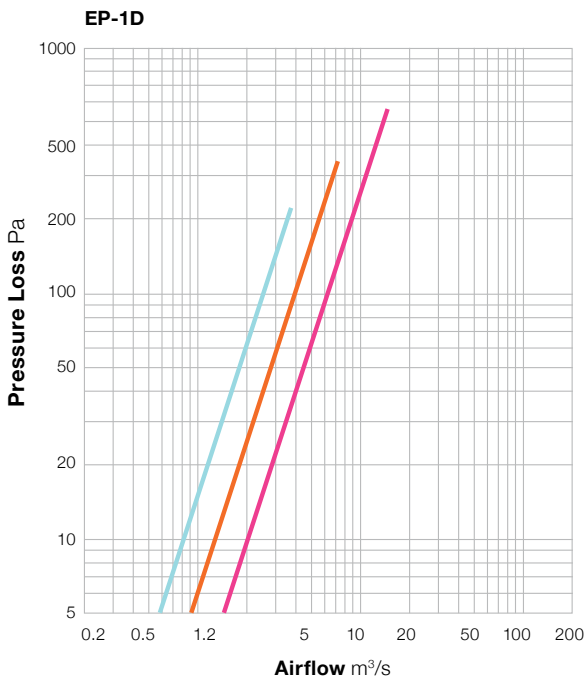

FLANGED SILENCER

Dimensional Data

Silencer 1DEP Podded

Product Code	Fan Dia	A	B	C	D	E	Weight kg
068-0400-1DEP	400	400	503	8	M10	450	16
068-0500-1DEP	500	500	657	12	M10	560	22
068-0630-1DEP	630	630	784	12	M10	690	31

Silencer 1DENP Unpodded

Product Code	Fan Dia	A	B	C	D	E	Weight kg
068-0400-1DENP	400	400	503	8	M10	450	13
068-0500-1DENP	500	500	657	12	M10	560	18
068-0630-1DENP	630	630	784	12	M10	690	26

Silencer 2DEP Podded

Product Code	Fan Dia	A	B	C	D	E	Weight kg
068-0400-2DEP	400	800	503	8	M10	450	26
068-0500-2DEP	500	1000	657	12	M10	560	37
068-0630-2DEP	630	1260	784	12	M10	690	57

Silencer 2DENP Unpodded

Product Code	Fan Dia	A	B	C	D	E	Weight kg
068-0400-2DENP	400	800	503	8	M10	450	22
068-0500-2DENP	500	1000	657	12	M10	560	32
068-0630-2DENP	630	1260	784	12	M10	690	48

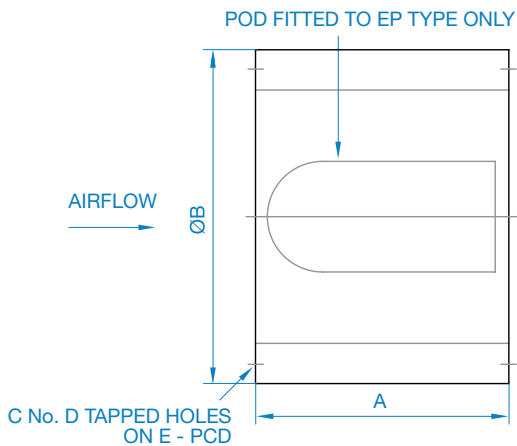

Dimensions are in mm.

HIGH TEMPERATURE FLEXIBLE CONNECTOR

Accessories

- Fit to matching flanges to provide flexible connection
- Polyurethane coated glass fiber fabric
- Supplied with plated steel band fixings
- Alternative materials available to order
- Suitable for -50°C and +200°C and up to 400°C / 2 hours



Product Code	Fan Dia. A	B	Weight kg
063-0400-PU250	400	150	0.9
063-0500-PU250	500	150	1.2
063-0630-PU250	630	200	1.4

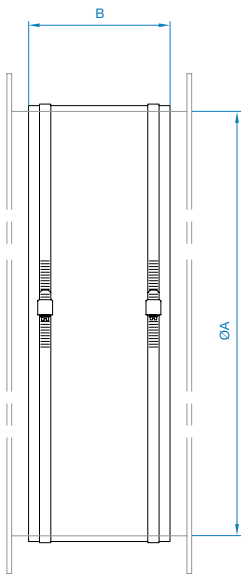

Dimensions are in mm.

IMPELLER SIDE GUARD

Accessories

- Powder coated polyester epoxy paint finish in RAL 7040 (Window Grey)
- Fix with clips & screw provided



Product Code	Fan Dia.	A	B	Weight kg
078C-0400-C	400	420	26	1.6
078C-0500-C	500	520	32	2.2
078C-0630-C	630	655	40	2.6

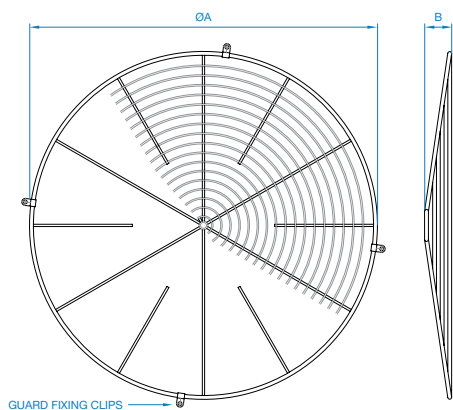

Dimensions are in mm.

MATCHING FLANGES

Accessories

- Fits directly to fan case flange
- Provides easy connection to flexible connector or ducting
- Hot dip galvanised steel



Product Code	Fan Dia. A	B	C	D	E	F	G	Weight kg
061B-0400	400	475	40	1.5	8	12	450	1.2
061B-0500	500	585	45	2.0	12	12	560	2.6
061B-0630	630	715	45	2.0	12	12	690	3.5

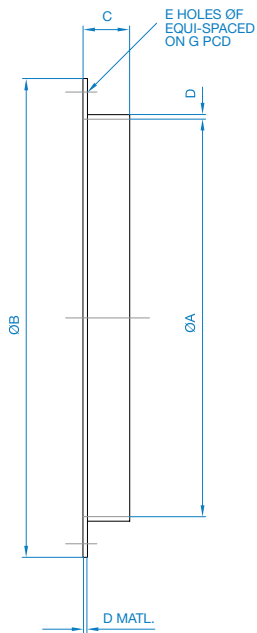

Dimensions are in mm.

MOUNTING FEET

Accessories

- For free standing mounting of ducted fans
- Fixes directly to fan case flange
- Hot dip galvanised steel



Product Code	Fan Dia.	A	B	C	D	E	F	G	H	Weight kg
060B-0400	400	250	350	400	230	50	27.5	4	9	1.5
060B-0500	500	315	450	500	290	50	27.5	4	11	2.5
060B-0630	630	400	580	630	375	60	32	5	11	5.0

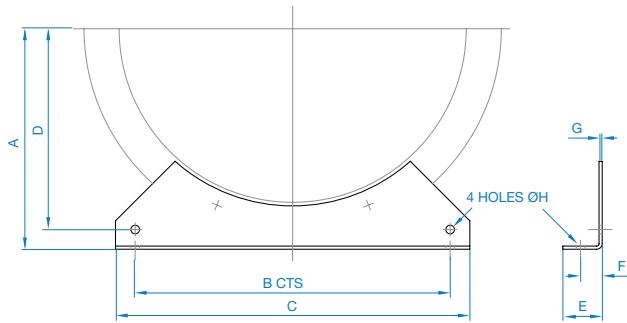

Dimensions are in mm.

Building Services

Tel **+44 (0) 1384 275800**
Fax **+44 (0) 1384 275810**
Email **info@eltafans.co.uk**

46 Third Avenue, Pensnett Trading Estate, Kingswinford,
West Midlands, DY6 7US United Kingdom

Applied Technology & Building Services Export

Tel **+44 (0) 1489 566500**
Fax **+44 (0) 1489 566555**
Email **at@eltafans.co.uk / export@eltafans.co.uk**

17 Barnes Wallis Road, Segensworth East Industrial Estate,
Fareham, Hampshire, PO15 5ST United Kingdom

eltafans.com

SBCYL-03-2018 Issue A



BS EN ISO 9001:2015 FM 556465

